



Digalox® DPM72-MPP

Instruction manual (Rev-2026-01)

Graphical panel meter with RGB backlight
for analogue signal 0/2 - 10 V and 0/4 - 20 mA

Package contents: Panel meter Digalox® DPM72-MPP, mounting bracket,
5 jumpers, 2 instruction manuals (EN + DE)

1. Safety instructions

- Read instruction manual carefully before operating the device! Keep for later reference.
- Mounting and installation must be carried out by suitably qualified and competent persons only.
- **When working on the device hazardous voltages must not be connected to the device! The jumper pins J1-J12 are not isolated from the measuring circuit.**
- **The device must not be used as the only protective device or protective shutdown.**
- The device is not intended to protect persons or facilities against harm. Specific devices must be used to guarantee safety (protection relays, cut-off switches, etc.).
- When connecting switches to the jumper pins J1-J8, only switches must be used whose isolation voltage is at least twice the maximum occurring measurement voltage. For example, when measuring 30 V DC switches must be isolated for at least 60 V.
- Do not open the housing!
- Do not use the device in the presence of explosive or flammable substances!
- All cables carrying hazardous voltages must be secured with external separators.

2. Meaning of symbols



General warning sign
(Attention, observe the documentation!)



Warning of an electrical hazard

3. Intended use

- Measurement of current and voltage in the specified measuring ranges for process signals
- Indoor use non condensing, non corrosive.
- Panel mounting.
- In operation, supply the device preferably via screw terminals with 12 to 24 V AC/DC instead of via USB.
- Failure to comply with these instructions will void all guarantee and warranty.

4. Description

The measurement types analogue signal 0/2 to 10 V and 0/4 to 20 mA DC are supported. The multi display with RGB backlight is able to display up to four parameters simultaneously. Thresholds can be associated with individual warning backlight colours. The device can be switched between the individual measurement functions during operation via a switching contact. Minimum and maximum values are recorded for the currently visible parameters and can be displayed and reset via a switching contact. Measured values are recorded over a time span of 36 seconds up to 14 days. The time base as well as the display of the measuring history can be switched via a switching contact. The measured values remain stored as long as the device is supplied with voltage.

The following settings can be adjusted via the “Digalox® Manager” configuration software: scale endpoint, scale caption, display style (pointer, tachometer, bar graph, and more), splash image, backlight colour, thresholds for alarm output, threshold warning colour (blinking or continuous light), hysteresis, and more. Recorded measurement values can be read and a continuous transmission of measurement values can be enabled. The measured values can be graphically analyzed within the software and exported as a CSV file. Depending on the model, measured values can be transmitted via USB, XBEE radio technology or RS485 Modbus interface. In addition, the devices feature a counting function with data retention. This enables operating-hours-counters or time-counters for exceeding and falling below threshold values, as well as single pulse counting.

In the “Downloads” area of www.digalox.com you can find the latest version of the instruction manual and the software “Digalox® Manager”.

5. Product overview

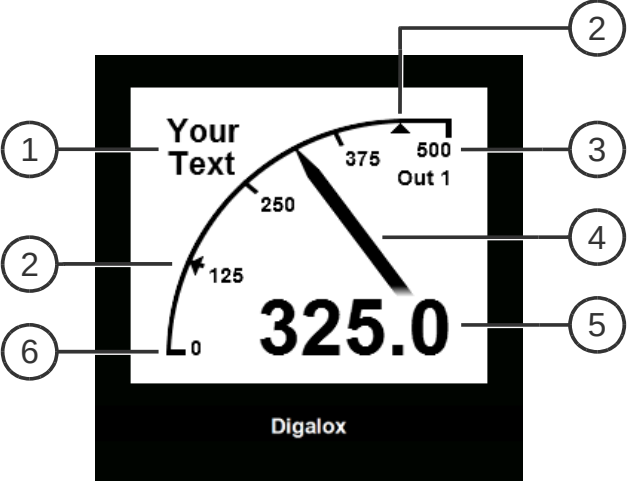
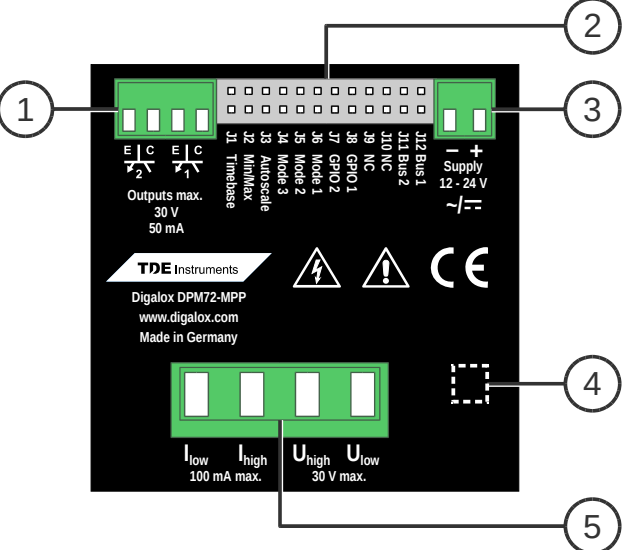
	<p>Front</p> <ol style="list-style-type: none"> 1 Unit or free text 2 Threshold values 3 Upper scale caption 4 Graphical measurement display 5 Digital measurement value 6 Lower scale caption
	<p>Back</p> <ol style="list-style-type: none"> 1 2 optocoupler switch outputs 2 Jumper pins J1–J12 for activating/switching of graphical historic data display, min/max display, auto-scaling, display value (mode), ... 3 Supply voltage input 4 Interface (USB Micro-B / XBEE / RS485) 5 Measurement inputs

6. Mounting

Carefully insert the device into the panel cut-out. Insert the mounting bracket from the back and push towards the panel until the device sits tight. Make sure the mounting bracket is snapped into the side of the housing. To ensure IP65 protection (dust and water jet) when mounting in a front panel, use optional gasket (separately available).

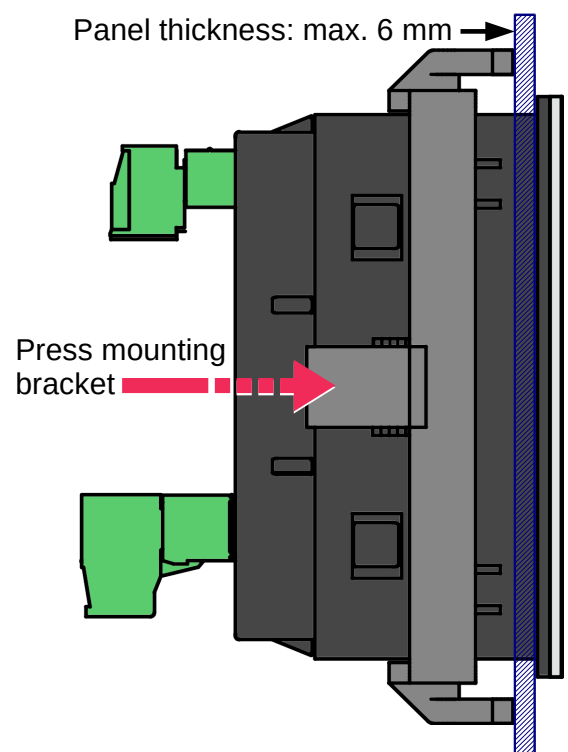

7. Electrical connections

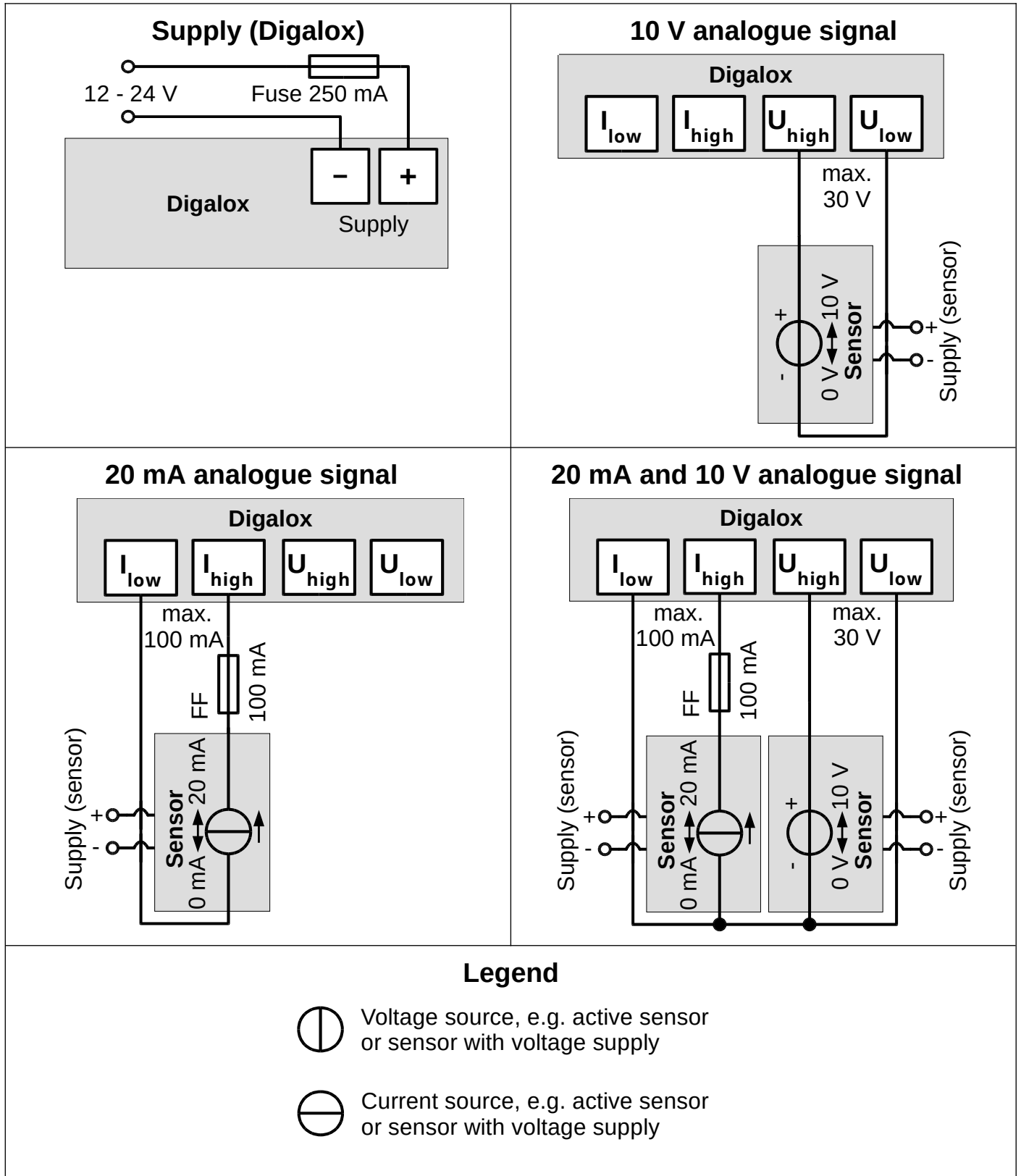

WARNING: The device may only be operated in one of the connection options shown above! Use an ultra-fast-acting fuse (FF) at the current measurement input.

If two sensors are used, both must be active. If one sensor is inactive, there must not be anything connected to the corresponding low measuring input, otherwise incorrect values will be measured.

8. Configuration

Connect the device to a computer:



USB: Connect the device and the computer using a USB cable. The device driver can be installed via Windows Device Manager or Windows Update (Optional updates) if it is not installed automatically.

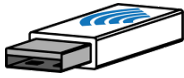

XBEE: Insert the XBEE stick into the computer. The device driver is installed automatically if the computer is connected to the Internet. In order to reset the XBEE settings, short-circuit jumper pins J8.



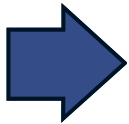

RS485: Short-circuit jumper pins J8. Disconnect the device from the Modbus network and connect it to the computer using an RS485 USB adapter. After completing the configuration, open J8 again.

Start the “Digalox[®] Manager” software and connect it to the device. Settings can then be made on the various tabs and saved in the device.

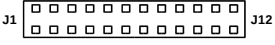
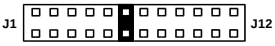
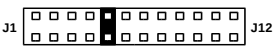

After restart, the device always shows the first display value or the one that is selected by the jumper pins J4-J6 (see table “display value”), in case of a multi display style additionally the following display values.

Table display value (factory preset, can be changed by software)

	Display value	Display	Selection
1	10 V DC scaled	10 V %	
2	2-10 V DC scaled	2-10 V %	
3	20 mA DC scaled	20 mA %	
4	4-20 mA DC scaled	4-20 mA %	

9. Other settings

The following functions can be activated independently during operation by short-circuiting jumper pins J1-J3, e.g. using a jumper or switch:

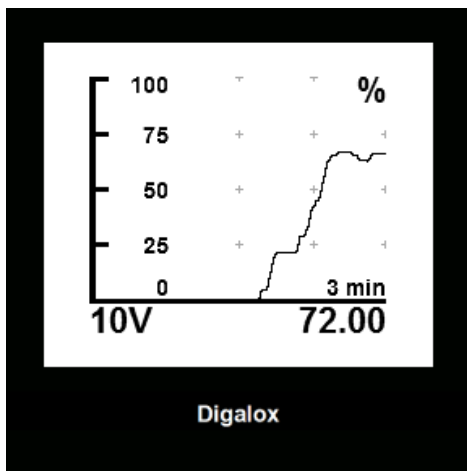

J1: Graphical historic data display

The unit displays the stored values within the set time base as a graphical trend. The time base can be set to days (7, 14), hours (1, 3, 6, 12, 24, 48, 72), minutes (3, 15, 30) or seconds (36).

The time base can be changed by alternately opening and closing J1 (interval < 2 sec). When first opening and closing J1 the current time base is displayed. For each subsequent opening and closing the time base changes to the next setting. In order to save the setting permanently, the software "Digalox® Manager" has to be used.

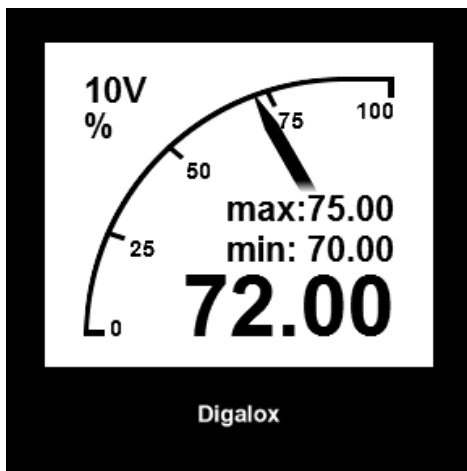

J2: Min-Max display

The display shows the maximum and minimum values recorded since the last reset. The values can be reset by opening and closing J2 shortly (interval < 2 sec). The display shows "Minmax reset". The values are also reset when switching the display value via J4-J6.

J3: Auto-scaling

The device automatically changes the upper scale caption depending on the current measuring value, e.g. between 10, 100 and the set upper scale caption.

10. Maintenance

Periodically check all external cable connections.

11. Cleaning

Observe the safety instructions before cleaning the device. Clean the device with a dry lint-free soft cloth. Do not use solvents.

12. Specification

Supply	12 - 24 V AC/DC $\pm 10\%$ (50/60 Hz $\pm 10\%$) or if applicable via USB, galvanically isolated
Required external fuse for supply	250 mA, fast (F)
Power consumption	Max. 2.4 W
Display	LCD graphic display 192 × 160 pixels, 16 grey levels with RGB backlight
Measuring range voltage	± 30 V DC, 20 V AC, 10 - 500 Hz
Accuracy voltage	± 0.5 % true RMS
Internal resistance voltage	102 k Ω
Measuring range ampere	20 mA AC/DC (max. 100 mA), 10 - 500 Hz
Accuracy ampere	$\pm 0,5$ % true RMS
Internal resistance ampere	6.2 Ω
Required external fuse for ampere	For rated current, ultrafast (FF)
Measuring value update	5 Hz (32 kHz sampling rate)
Recording of measurement	36 seconds to 14 days, 180 internal memory locations
Alarm outputs	2 optocoupler outputs, max. 30 V DC, 50 mA
Permissible voltage between supply and measuring inputs	< 50 V AC, < 75 V DC
Connections (measuring inputs) - Wire gauge - Wire strip length - Pitch	0.2 - 3.3 mm ² (24 to 12 AWG) 7 - 8 mm 7.62 mm
Connections (supply, alarm outputs and RS485) - Wire gauge - Wire strip length - Pitch	0.13 - 1.3 mm ² (26 to 16 AWG) 6 - 7 mm 3.5 mm
Operating temperature	0 °C to +50 °C
Storage temperature	-20 °C to +70 °C
Operating altitude	0 to 2000 m above sea level
IP code	IP65 (front), IP00 (back)
Dimensions	72 mm × 72 mm × 58 mm
Panel cut-out	68 mm × 68 mm

Mounting depth	55.3 mm (with plugs, cable direction rear facing) 72.6 mm (with antenna)
Net weight	148 g

13. Dimensions [mm]

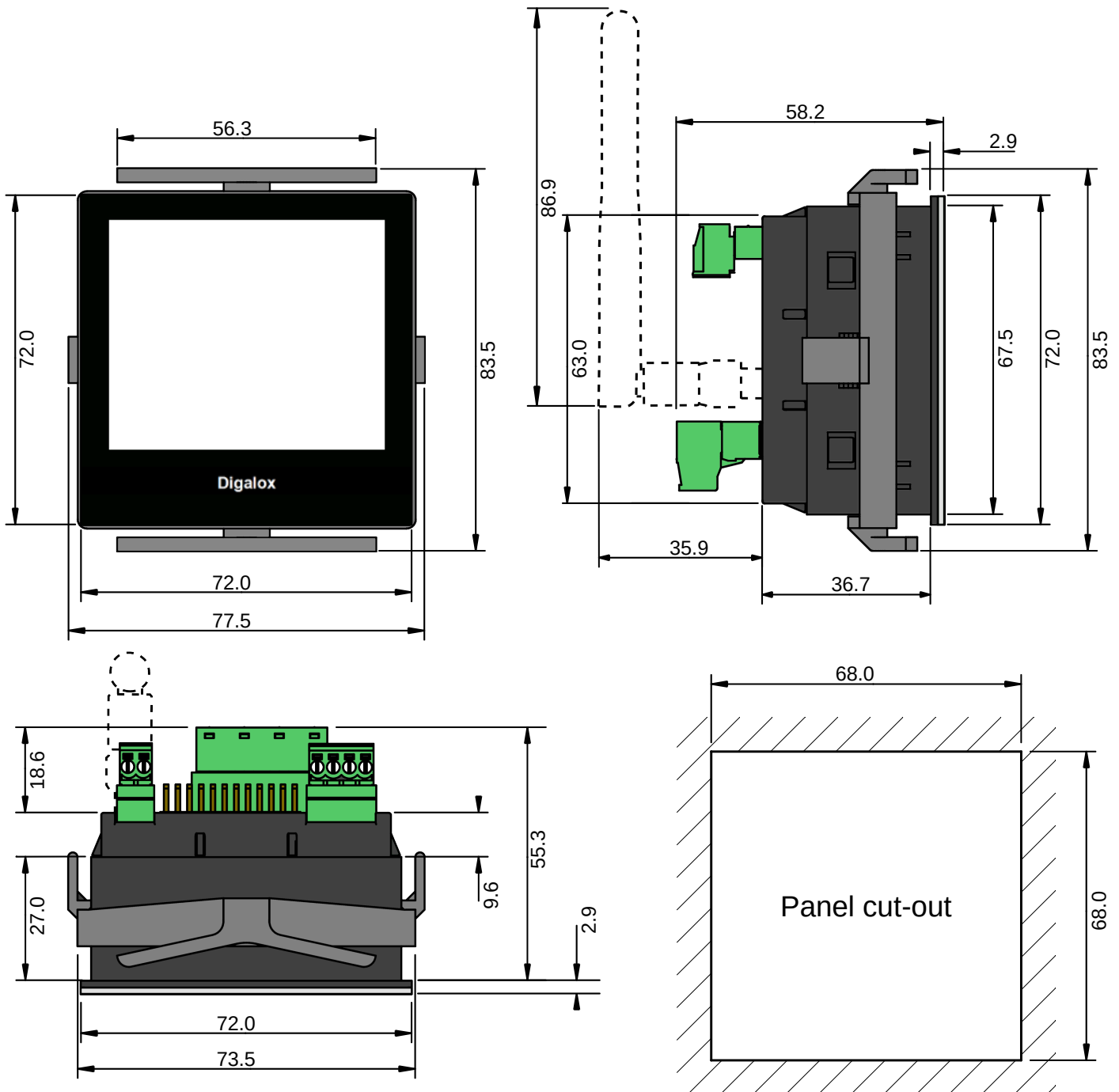

14. Available accessories

TDE Instruments Digalox® DPM72 gasket EPDM/SBR

15. Contact information

TDE Instruments GmbH, Gewerbestraße 8, D-71144 Steinenbronn

Phone: +49 7157 20801, Technical support: +49 351 84127746

E-mail: info@tde-instruments.de

Internet: www.tde-instruments.de, www.digalox.com