

Digalox® DPM72-AVP Instruction manual (Rev-2026-01)

In the “Downloads” area of **www.digalox.com** you can find the latest version of the instruction manual and the software “Digalox® Manager”.

Package contents: Panel meter Digalox® DPM72-AVP, mounting bracket, 5 jumpers, 2 instruction manuals (EN + DE)

1. Intended Use

- Measurement of current, voltage and frequency in the specified measuring ranges.
- Indoor use non condensing, non corrosive.
- Panel mounting.
- Failure to comply with these instructions will void all guarantee and warranty.
- In operation, supply the device preferably via screw terminals with 12 to 24 V AC/DC instead of via USB.

2. Safety instructions

- Read instruction manual carefully before operating the device! Keep for later reference.
- Mounting and installation must be carried out by suitably qualified and competent persons only.
- **WARNING: The measurement inputs of the device can carry life-threatening voltages!**
- **WARNING: When working on the device hazardous voltages must not be connected to the device! The jumper pins J1-J6 are not isolated from the measuring circuit.**
- **The device must not be used as the only protective device or protective shutdown.**
- The device is not intended to protect persons or facilities against harm. Specific devices must be used to guarantee safety (protection relays, cut-off switches, etc.).
- When connecting switches to the jumper pins J1-J6, only switches must be used whose isolation voltage is at least twice the maximum occurring measurement voltage. For example, when measuring 250 V AC switches must be isolated for at least 500 V.
- Do not open the housing!
- Do not use the device in the presence of explosive or flammable substances!
- All cables carrying hazardous voltages must be secured with external separators

3. Description

The measurement types volt AC/DC, ampere AC/DC, frequency and 5 A or 1 A for current transformer are supported. The device can be switched between the individual measurement functions during operation via a switching contact. Minimum and maximum values are recorded for the currently visible parameter and can be displayed and reset via a switching contact. Measured values are recorded over a time span of 36 seconds up to 14 days. The time base as well as the display of the measuring history can be switched via a switching contact. The measured values remain stored as long as the device is supplied with voltage. The following settings can be adjusted via the “Digalox® Manager” configuration software: scale endpoint, scale caption, display style (pointer, tachometer, bar graph, and more), splash image, thresholds for alarm output, hysteresis, and more. Recorded measurement values can be read and a continuous transmission of measurement values can be enabled. The measured values can be graphically analyzed within the software and exported as a CSV file.

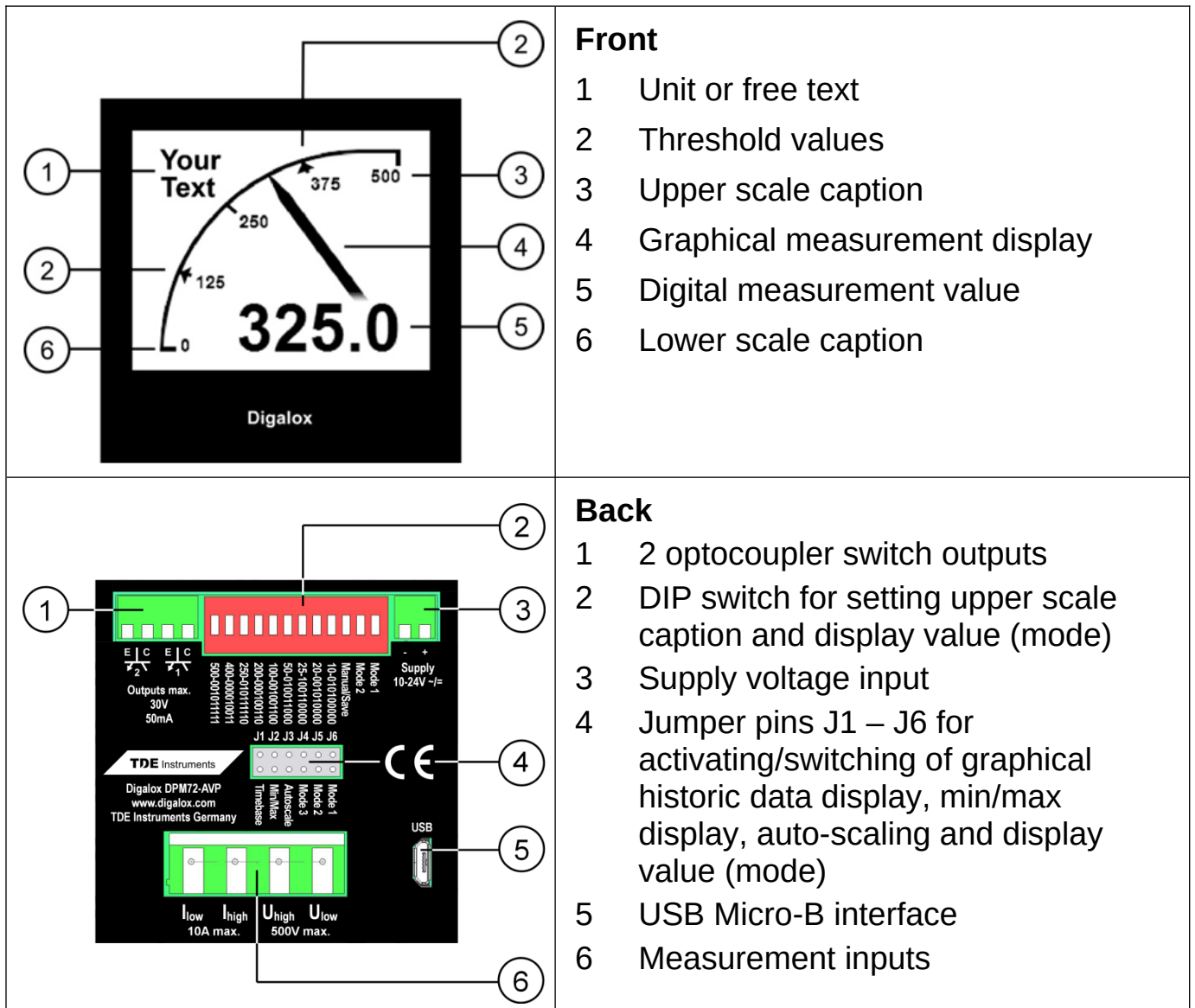

4. Electrical Connections

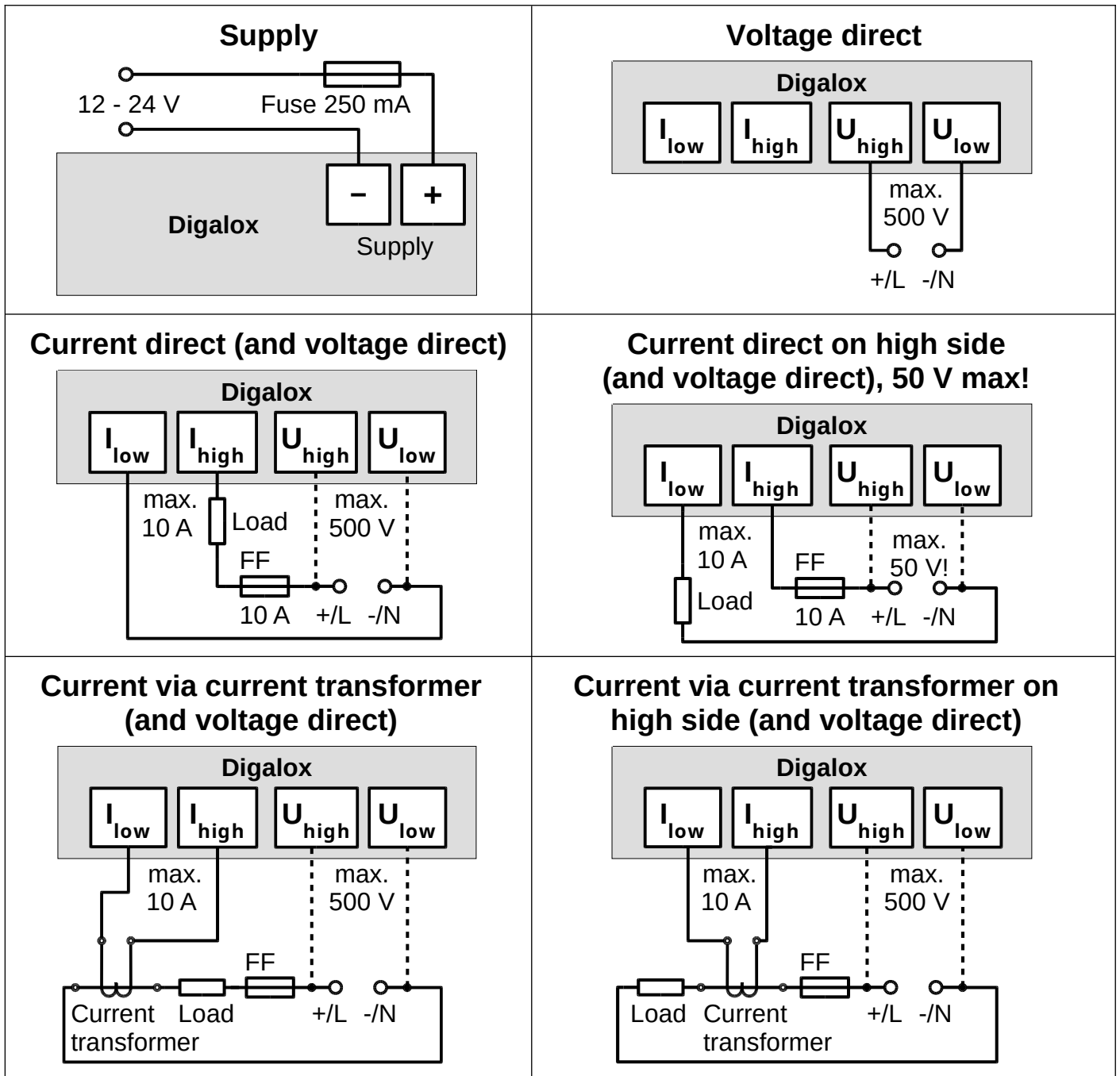

WARNING: The device may only be operated in one of the connection options shown above! Use an ultra-fast-acting fuse (FF) at the current measurement input.



DANGER: Direct current measurement on the high side (between plus and load) only for voltages up to 50 V! In this case the entire device is on high potential. Particularly to be considered when connecting switches to J1-6.

5. Configuration

The device can be configured via DIP switches and jumpers manually or with the corresponding software “Digalox® Manager” via USB interface. When configuring via DIP switches and jumpers the basic settings can be made computer-independent. The configuration with the software “Digalox® Manager” allows full functionality.

Configuration via USB interface with software “Digalox® Manager”

For configuration with software set DIP switch 10 to OFF position.

Connect the device to the computer via USB. The device driver can be installed via Windows Device Manager or Windows Update (Optional updates) if it is not installed automatically. After the installation of the driver, connect the device to the “Digalox® Manager”. Settings can then be made on the various tabs and saved in the device.

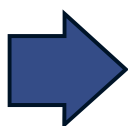

After restart, the device always shows the first display value or the one that is selected by the jumper pins J4-J6 or the DIP switches 11-12 respectively (see table “display value”).

Scaling via DIP switches

If the scaling to represent the correct display value (e.g. for 5 A AC for current transformer) is set via DIP switches the upper scale caption (upper display value) corresponds to the primary value of the current transformer.

Example:

upper scale caption = 50 = primary value of the current transformer

Configuration of display value via DIP switches and jumpers if only one display value is required (Manual mode)

1. Set DIP switch 10 to ON position.
2. Set display value with jumpers at J4-J6 according to table “display value”, column “Manual mode”.
3. Set upper scale caption for the first display value with DIP switches 1-9 (see “Configuration of the upper scale caption”).
4. Connect supply voltage.

Configuration of display values via DIP switches and jumpers if it is required to switch between multiple display values via an external switch (Save mode)

The required display values are configured and saved sequentially.

1. Set DIP-switch 10, 11 and 12 to OFF position.
2. Connect supply voltage.
3. Set the display value with jumpers at J4-J6 according to table “display value”, column “Save mode”.
4. Set DIP switch 10 to ON position.
5. Set upper scale caption for the first display value with DIP switches 1-9 (see “Configuration of the upper scale caption”).
6. Set time base for graphical historic data display (optional, see “Other settings”).
7. Set DIP switch 10 to OFF position.
8. “Saved” appears on the display. The configuration of the first display value is now completed.
9. When using multiple display values repeat steps 3-8 until all required display values are configured. The time base does not need to be set again, as it is used for all display values.
10. In operation the display values can be changed with a switch at J4-J6 according to table “display value”, column “Save mode”.

Configuration of the upper scale caption

The upper scale caption is binary coded using DIP switches 1-9. Possible values are 1 to 500. Switch 1 corresponds to 256, switch 2 corresponds to 128, switch 3 corresponds to 64, etc., switch 9 corresponds to 1. For configuration, proceed as follows:

1. Connect supply voltage.
2. Set DIP switches 1-9 to OFF position.
3. Set DIP switch 10 to ON position.
4. Start with 1st switch.
5. Set switch to ON position.
6. If the displayed value is greater than the desired value, set the switch back to OFF position.
7. If the displayed value is less than the desired value, leave the switch in ON position and move on to the next switch.
8. Repeat steps 5 to 7 until the desired value is displayed.

Table common switch combinations (DIP switch 1-9)



Value	Combination	Value	Combination
10		150	
20		200	
25		250	
50		400	
100		500	

Table display value (factory preset, can be changed by software)

Display value	Display	Scale	Manual mode	Save mode
V AC direct	Volt AC			
A AC direct	Ampere AC			
V DC direct	Volt DC			
A DC direct	Ampere DC			
AC Frequency	Freq. Hz			
5 A AC scaled (Current transformer)	Ampere CT	Upper scale caption		
1 A AC scaled (Current transformer)	Ampere CT	Upper scale caption		

6. Other settings

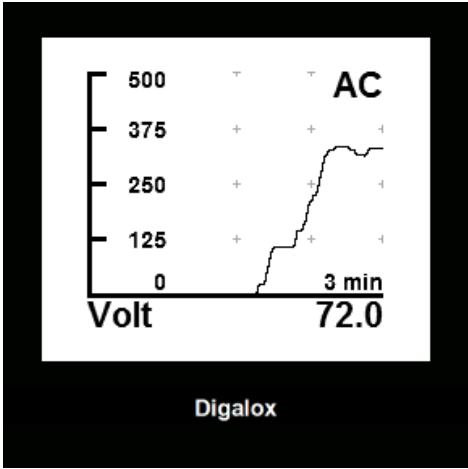
The following functions can be activated independently by short-circuiting jumper pins J1-J3 by jumper or switch during operation:

	<p>J1: Graphical historic data display</p> <p>The unit displays the stored values within the set time base as a graphical trend. The time base can be set to days (7, 14), hours (1, 3, 6, 12, 24, 48, 72), minutes (3, 15, 30) or seconds (36).</p> <p>The time base can be changed by alternately opening and closing J1 (interval < 2 sec). When first opening and closing J1 the current time base is displayed. For each subsequent opening and closing the time base changes to the next setting. In order to save the setting permanently, the software "Digalox® Manager" has to be used.</p>
	<p>J2: Min-Max-display</p> <p>The display shows the maximum and minimum values recorded since the last reset. The values can be reset by opening and closing J2 shortly (interval < 2 sec). The display shows "Minmax reset". The values are also reset when switching the display value via J4-J6.</p>
	<p>J3: Auto-scaling</p> <p>The device automatically changes the upper scale caption depending on the current measuring value, e.g. between 10, 100 and the set upper scale caption.</p>

7. Mounting

Carefully insert the device into the panel cut-out. Insert the mounting bracket from the back and push towards the panel until the device sits tight. Make sure the mounting bracket is snapped into the side of the housing. To ensure IP65 protection (dust and water jet) when mounting in a front panel, use optional gasket (separately available).

8. Cleaning

Observe the safety instructions before cleaning the device. Clean the device with a dry lint-free soft cloth. Do not use solvents.

9. Specification

Supply	12 - 24 V AC/DC $\pm 10\%$ (50/60 Hz $\pm 10\%$) or via USB, galvanically isolated
Required external fuse for supply	250 mA, fast (F)
Power consumption	Max. 1.2 W
Display	LCD graphic display 192 × 160 pixels
Measuring range voltage	± 500 V AC/DC, 10 - 500 Hz
Accuracy voltage	± 1 % true RMS
Internal resistance voltage	2.6 M Ω
Measuring range ampere	± 10 A AC/DC and 5 A AC for current transformer, 10 - 500 Hz
Accuracy ampere	± 1 % true RMS
Internal resistance ampere	5 m Ω
Required external fuse for ampere	For rated current, ultrafast (FF)
Measuring range frequency	10 - 1000 Hz
Accuracy frequency	± 0.1 Hz
Measuring value update	5 Hz (32 kHz sampling rate)
Recording of measurement	36 seconds to 14 days, 180 internal memory locations
Alarm outputs	2 optocoupler outputs, max. 30 V DC, 50 mA
Operating temperature	0 °C to +50 °C
Storage temperature	-20 °C to +70 °C
Operating altitude	0 to 2000 m above sea level
IP code	IP65 (front), IP00 (back)
Dimensions	72 mm × 72 mm × 54.8 mm
Panel cut-out	68 mm × 68 mm
Mounting depth	51.8 mm
Net weight	145 g

10. Available accessories

- TDE Instruments Digalox[®] DPM72 gasket EPDM/SBR
- ENTES ENT.A Current transformer with 5 A secondary current

11. Contact Information

TDE Instruments GmbH, Gewerbestraße 8, D-71144 Steinenbronn
Phone: +49 7157 20801, Technical support: +49 351 84127746
E-mail: info@tde-instruments.de
Internet: www.tde-instruments.de, www.digalox.com