



## Digalox® DPM36-P

### Instruction manual (Rev-2026-04)

Panel meter for 30V/100mA AC/DC

**Package contents:** Panel meter Digalox® DPM36, 5 jumpers,  
2 instruction manuals (EN+DE)

## 1. Safety instructions

- Read instruction manual carefully before operating the device! Keep for later reference.
- Mounting and installation must be carried out by suitably qualified and competent persons only.
- **WARNING: When working on the device hazardous voltages must not be connected to the device! The jumper terminals are not isolated from the measuring circuit.**
- **DANGER: When the USB port is connected, only voltages less than 50 V may be present at the measurement inputs. The USB port is not isolated from the measuring circuit.**
- The device is not intended to protect persons or facilities against harm. Specific devices must be used to guarantee safety (protection relays, cut-off switches, etc.).
- When connecting switches to the jumper terminals, only switches must be used whose isolation voltage is at least twice the maximum occurring measurement voltage. For example, when measuring 30 V DC switches must be isolated for at least 60 V.
- Do not use the device in the presence of explosive or flammable substances!
- All cables carrying hazardous voltages must be secured with external separators.

## 2. Meaning of symbols



General warning sign  
(Attention, observe the documentation!)

### 3. Intended use

- Measurement of current, voltage and frequency in the specified measuring ranges.
- Indoor use non condensing, non corrosive.
- Panel mounting.
- In operation, supply the device preferably via screw terminals with 8 to 24 V DC instead of via USB.
- Failure to comply with these instructions will void all guarantee and warranty.

### 4. Product overview

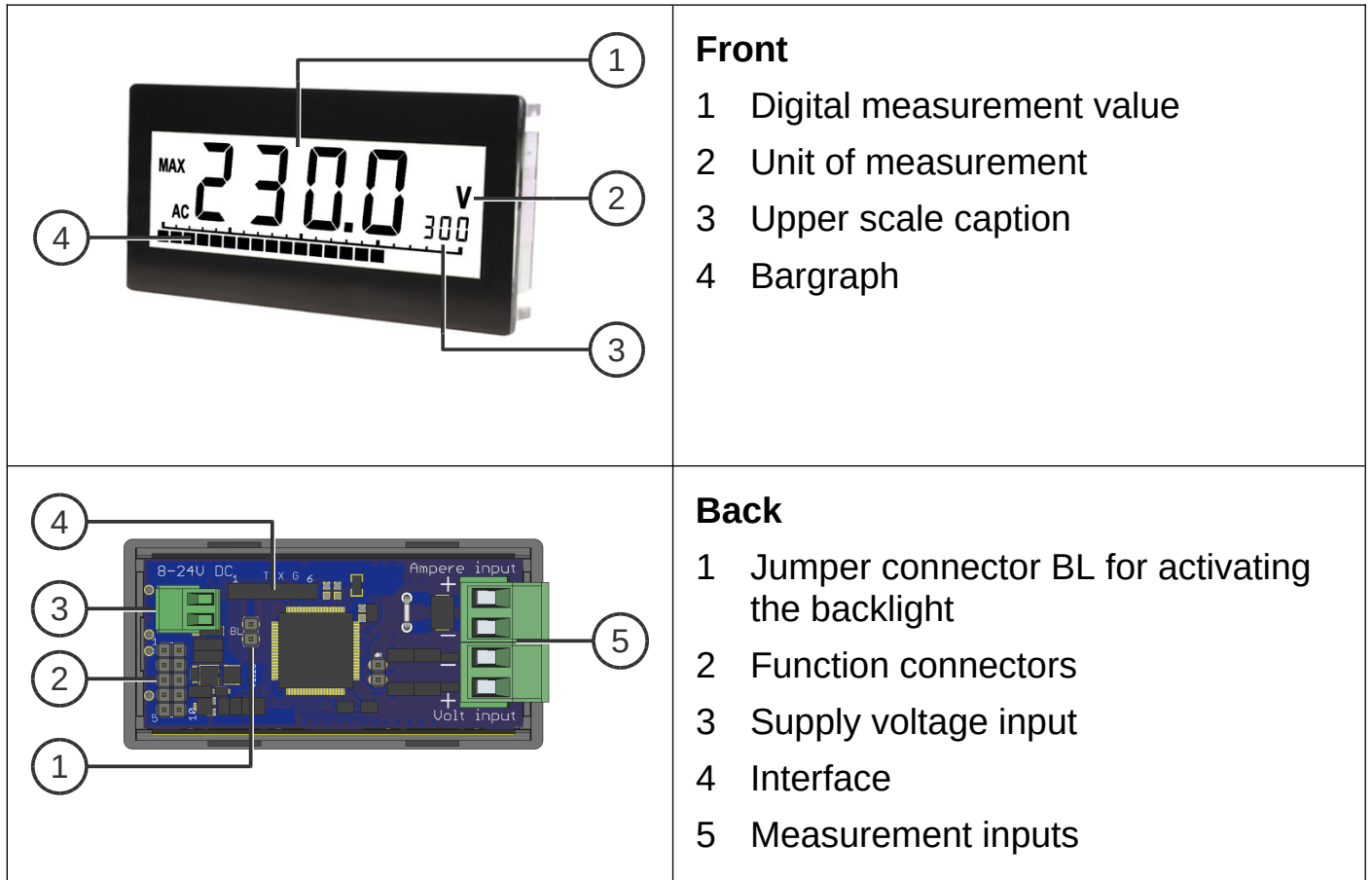

### 5. Description

The measurement types volt AC/DC, ampere AC/DC and frequency are supported. During operation, it is possible to switch between four measurement modes using a switch contact. The currently measured value can be frozen using a switch contact (hold function). Min and max values are recorded. They can be displayed using a switch contact and reset by changing the measurement mode or restarting. The backlight can be switched on or off using a switch contact.

A programming menu that can be operated using a jumper allows further settings. The full scale of the bar display can be programmed for each measurement mode. The measurement type can be changed for each measurement mode. In addition, a scaling factor can be selected for each measurement mode. For battery operation, the supply

voltage is monitored, which generates a warning message on the display if an adjustable threshold is undershot. The device can be reset to factory settings.

The measured values can be continuously transmitted together with min and max values via the UART interface or via the optionally available USB card. In addition, further programming can be carried out using interface commands, e.g. the selection of the symbols to be displayed.

**Note:** The device displays the measured values directly or scaled by a factor. The factor can be selected from a predefined set of factors. For general linear mappings, e.g., mapping 2–10 V to 0–100, the interface must be used.

## 6. Mounting

Carefully insert the device into the panel cut-out from the front and press it towards the panel until the device sits tight. The device is held in place by 4 locking lugs. To ensure IP65 protection (dust and water jet) when mounting in a front panel, use a gasket. Panel thickness: max. 3 mm.

## 7. Electrical connections

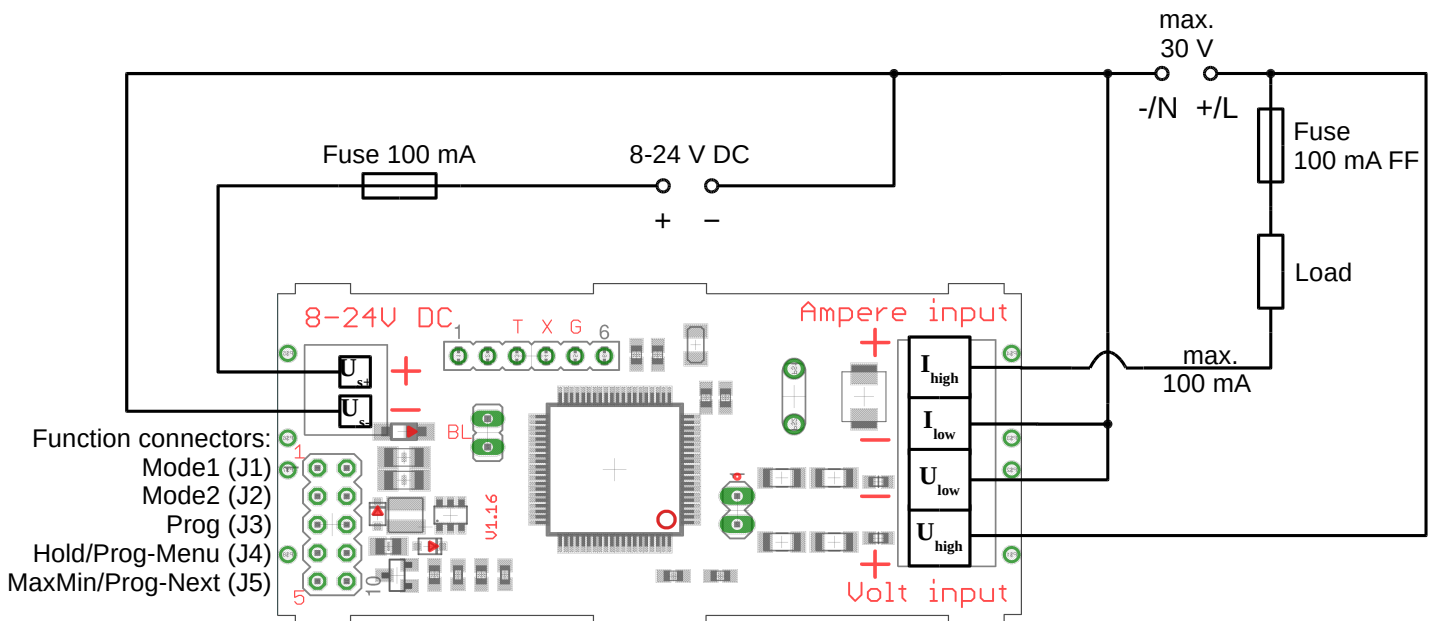

## 8. Features

During operation, the following functions can be activated independently of each other by short-circuiting the pins of the corresponding function connectors (BL and J1 – J5), e.g. using a jumper or switch:

### Backlight

Set jumper to BL: Backlight active

### Measurement mode

Set jumpers to Mode1/Mode2:

Measurement mode	Mode1 (J1)	Mode2 (J2)	Measurement type (factory preset)
1			Volt DC
2	x		Volt DC
3		x	Ampere DC
4	x	x	Ampere DC

### Hold

Set jumper to Hold: The current display value is frozen until the jumper is removed or the device is restarted.

### Max/Min mode

1. Set jumper to MaxMin, display shows maximum value
2. Remove jumper, display shows measured value
3. Set jumper to MaxMin, display shows minimum value
4. Remove jumper, display shows current measured value

## 9. Configuration

The device can be configured using a jumper or with the corresponding software "Digalox® DPM36 Config" via the interface. Basic settings can be configured independently of a computer using a jumper. Configuration via the software enables the full range of functionality. The configuration using a jumper is described in more detail below.

Set the mode to be configured at Mode1 and Mode2 using jumpers. Only one additional jumper is required for the following programming.

### Upper scale caption

(Full scale of the bar graph, possible values: 0-990)

1. Set jumper to Prog, display shows "Prog" and then "bAr"
2. Remove jumper
3. Set jumper to Prog-Next, display shows "bAr", upper scale caption flashes

4. First select the range 0-99 or 100-990 by setting jumper to Prog-Next. (The third digit can only be 0. It is simply made visible or invisible.)
5. Switch to the first digit by setting jumper to Prog-Menu
6. Change the first digit by setting jumper to Prog-Next
7. Switch to the second digit by setting jumper to Prog-Menu
8. Change the second digit by setting jumper to Prog-Next
9. Set jumper to Prog, display shows "Save"
10. Remove jumper

### **Measurement type**

(Possible values: Volt AC, Ampere AC, Volt DC, Ampere DC, Hertz at the voltage input)

1. Set jumper to Prog, display shows "Prog" and then "bAr"
2. Remove jumper
3. Set jumper to Prog-Menu, display shows "Type"
4. Select measurement type by setting jumper to Prog-Next
5. Set jumper to Prog, display shows "Save"
6. Remove jumper

### **Scaling factor**

(Factor by which the measured value is multiplied for display. Possible values: 1, 2, 3, 4, 5, 6, 10, 15, 20, 25, 30, 50, 100, 125, 150, 200, 250, 300, 400, 500, 600, 700, 800, 900, 1000)

1. Set jumper to Prog, display shows "Prog" and then "bAr"
2. Remove jumper
3. Set jumper to Prog-Menu, display shows "Type"
4. Remove jumper
5. Set jumper to Prog-Menu, display shows "Fctr"
6. Change scaling factor by setting jumper to Prog-Next (1-1000)
7. Set jumper to Prog, display shows "Save"
8. Remove jumper

### **Supply monitoring threshold**

(Value of the supply voltage, below which a warning is displayed)

1. Set jumper to Prog, display shows "Prog" and then "bAr"
2. Remove jumper
3. Set jumper to Prog-Menu, display shows "Type"
4. Remove jumper
5. Set jumper to Prog-Menu, display shows "Fctr"
6. Remove jumper
7. Set jumper to Prog-Menu, display shows "SPLY"

8. Set jumper to Prog-Next, display shows threshold
9. Change the flashing digit by setting jumper to Prog-Next (0-9)
10. Switch to another digit by setting jumper to Prog-Menu
11. Repeat steps 9 and 10 until the threshold is set
12. Set jumper to Prog, display shows "Save"
13. Remove jumper

### Reset to factory settings

1. Set jumper to Prog, display shows "Prog" and then "bAr"
2. Remove jumper
3. Set jumper to Prog-Menu, display shows "Type"
4. Remove jumper
5. Set jumper to Prog-Menu, display shows "Fctr"
6. Remove jumper
7. Set jumper to Prog-Menu, display shows "SPLY"
8. Remove jumper
9. Set jumper to Prog-Menu, display shows "dFlt"
10. Set jumper to Prog, display shows "Save"
11. Remove jumper

## 10. Maintenance

Periodically check all external cable connections.

## 11. Cleaning

Observe the safety instructions before cleaning the device. Clean the device with a dry lint-free soft cloth. Do not use solvents.

## 12. Specification

Supply	8 - 24 V DC $\pm 10\%$
Backlight supply	Via main supply, activated by jumper
Required external fuse for supply	100 mA, fast (F)
Power consumption	Max. 0.5 W
Main display	4-digit LCD, 12.3 mm digit height
Bargraph display	21 segments, upper scale caption 2-digit plus 0 (0-990)
Measuring range voltage	$\pm 30$ V DC, 20 V AC, 10 - 500 Hz
Accuracy voltage	$\pm 1$ % true RMS
Internal resistance voltage	200 k $\Omega$
Measuring range ampere	20 mA AC/DC (max. 100 mA), 10 - 500 Hz
Accuracy ampere	$\pm 1$ % true RMS
Internal resistance ampere	1,2 $\Omega$
Required external fuse for	For rated current, ultrafast (FF)

ampere	
Measuring range frequency	10 - 3000 Hz
Accuracy frequency	±1 %
Measuring value update	5 Hz (16 kHz sampling rate)
Connections (measuring inputs) - Wire gauge - Wire strip length - Pitch	0.2 – 2.5 mm <sup>2</sup> (28 - 12 AWG) 7 mm 5.08 mm
Connections (supply) - Wire gauge - Wire strip length - Pitch	0.13 – 1.3 mm <sup>2</sup> (26 - 16 AWG) 6 - 7 mm 3.5 mm
Operating temperature	0 °C to +50 °C
Storage temperature	-20 °C to +70 °C
Operating altitude	0 to 2000 m above sea level
IP code	IP65 (front), IP00 (back)
Dimensions	36 mm × 72 mm × 34 mm
Panel cut-out	33 mm × 68 mm
Mounting depth	30 mm (with plugs, cable direction rear facing)
Net weight	44 g

### 13. Dimensions [mm]

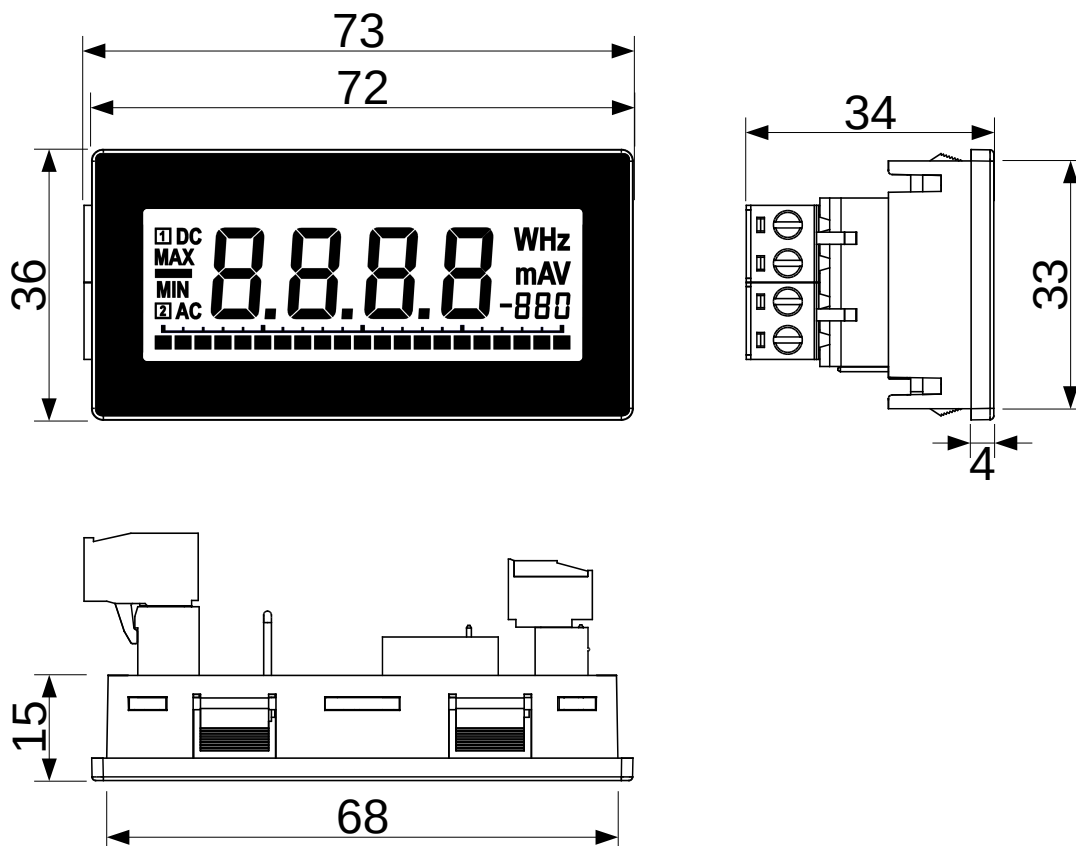

### 14. Available accessories

- TDE Instruments Digalox<sup>®</sup> EX-USB USB interface

## **15. Contact information**

TDE Instruments GmbH, Gewerbestraße 8, D-71144 Steinenbronn

Phone: +49 7157 20801, Technical support: +49 351 84127746

E-mail: [info@tde-instruments.de](mailto:info@tde-instruments.de)

Internet: [www.tde-instruments.de](http://www.tde-instruments.de), [www.digalox.com](http://www.digalox.com)